

# WALTHER FLENDER 锥套

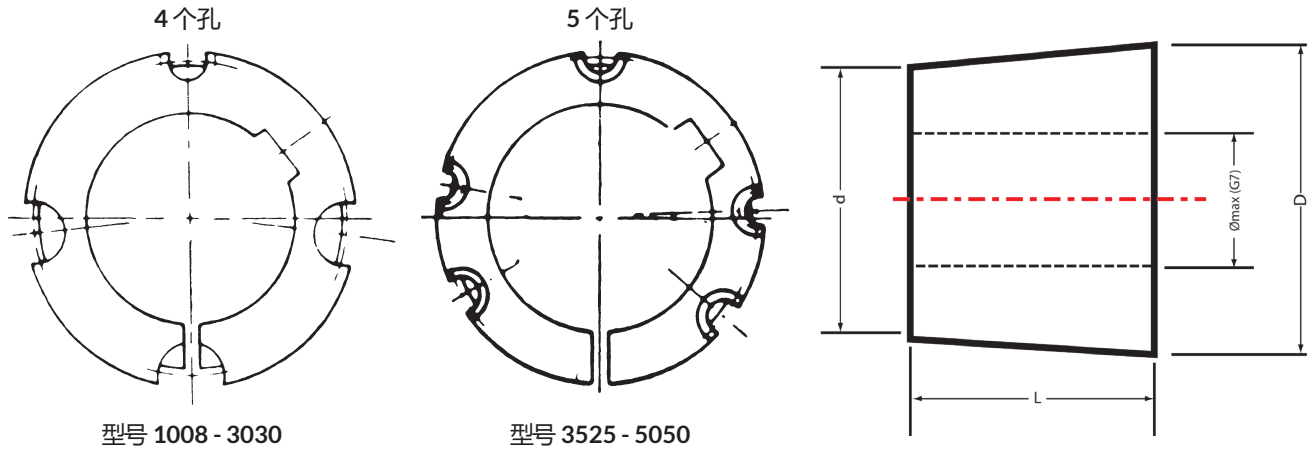

## 对应参数

型号	锥套孔径 (mm)	键槽 (mm)		锥套			轴套最小尺寸. Ø		螺钉尺寸 d x l x sw BSW x mm		
		宽度	深度	最大 孔径-Ø	L	D	d	GG		ST	
1008	10	3	1.4	25	20.3	35.20	32	55	49	2 颗螺钉	$\frac{1}{4} \cdot \frac{1}{2} \cdot 3$
	11 12	4	1.8								
	14 16	5	2.3								
	18 19 20 22	6	2.8								
	24 25	8	1.3*								
1108	10	3	1.4	28	20.3	38.38	36	60	52		
	11 12	4	1.8								
	14 16	5	2.3								
	18 19 20 22	6	2.8								
	24 25	8	3.3								
1210	11 12	4	1.8	32	25.4	47.62	44	80	73		
	14 16	5	2.3								
	18 19 20 22	6	2.8								
	24 25 28 30	8	3.3								
	32	10	3.3								
1215	14 15 16	5	2.3	32	38.1	47.62	42	73	67		
	18 19 20 22	6	2.8								
	24 25 28 30	8	3.3								
	32	10	2.4*								
	1310	14 15 16	5							2.3	42
18 19 20 22		6	2.8								
24 25 28 30		8	3.3								
32 35 38		10	3.3								
40 42		12	3.3								
1610	14 16	5	2.3	42	38.1	57.15	52	82	76		
	18 19 20 22	6	2.8								
	24 25 28 30	8	3.3								
	32 35 38	10	3.3								
	40 42	12	1.3*								
2012	14 16	5	2.3	50	30.5	69.85	66	110	98		
	18 19 20 22	6	2.8								
	24 25 28 30	8	3.3								
	32 35 38	10	3.3								
	40 42	12	3.3								
2517	16	5	2.3	65	43.2	85.73	80	125	111		
	18 19 20 22	6	2.8								
	24 25 28 30	8	3.3								
	32 35 38	10	3.3								
	40 42	12	3.3								
	45 48 50	14	3.8								
	55	16	4.3								
60 65	18	4.4									
3020	25 28 30	8	3.3	75	50.8	107.95	101	155	143		
	32 35 38	10	3.3								
	40 42	12	3.3								
	45 48 50	14	3.8								
	55	16	4.3								
	60 65	18	4.3								
70 75	20	4.9									



## 力的数据

型号	锥套孔径 (mm)	锁紧扭矩 (Nm)		负载扭矩		夹紧力 (N)			
				无键槽 (Nm)	有键槽 (Nm)				
1008	12	6 (5) 1/4" sw 3	2 颗螺栓	22	136	3990			
	19			37		4940			
	24			58		5490			
1108	19	6 (5) 1/4" sw 3		2 颗螺栓	40	147	4630		
	24				62		5220		
	28				71		5720		
1210 1215	16	20 (16) 3/8" sw 5			2 颗螺栓	82	407	8840	
	19					105		9800	
	24					140		10900	
	32					180		12300	
1310	14	20 (16) 3/8" sw 5				2 颗螺栓	59	435	7800
	25						120		10900
	35		210				12500		
1610	19	20 (16) 3/8" sw 5	2 颗螺栓				98	486	8500
	24						135		9670
	38			240			11900		
	42			265			12700		
2012	24	30 (27) 7/16" sw 5		2 颗螺栓			165	808	11500
	38				310		14400		
	50				420		16700		
2517 2525	38	49 (40) 1/2" sw 6			2 颗螺栓		380	1311	17000
	48						510		19200
	60					690	22300		
3020 3030	38	90 (75) 5/8" sw 8				2 颗螺栓	480	2712	23900
	48						600		26100
	60		900				31500		
	75		1300				34500		
3525 3535	42	115 (100) 1/2" sw 10	3 颗螺栓				700	5062	41000
	60						1450		49800
	90			2300			59000		
4030 4040	48	170 (150) 5/8" sw 12		3 颗螺栓			1250	8735	68000
	75						2200		77200
	100				3460		89400		
4535 4545	55	190 (160) 3/4 sw 14			3 颗螺栓		1840	12430	79600
	75						3000		93000
	100					4500	107700		
5040 5050	75	270 (230) 7/8" sw 14				3 颗螺栓	3250	14238	91800
	100						4800		106600
	125						5900		119500